

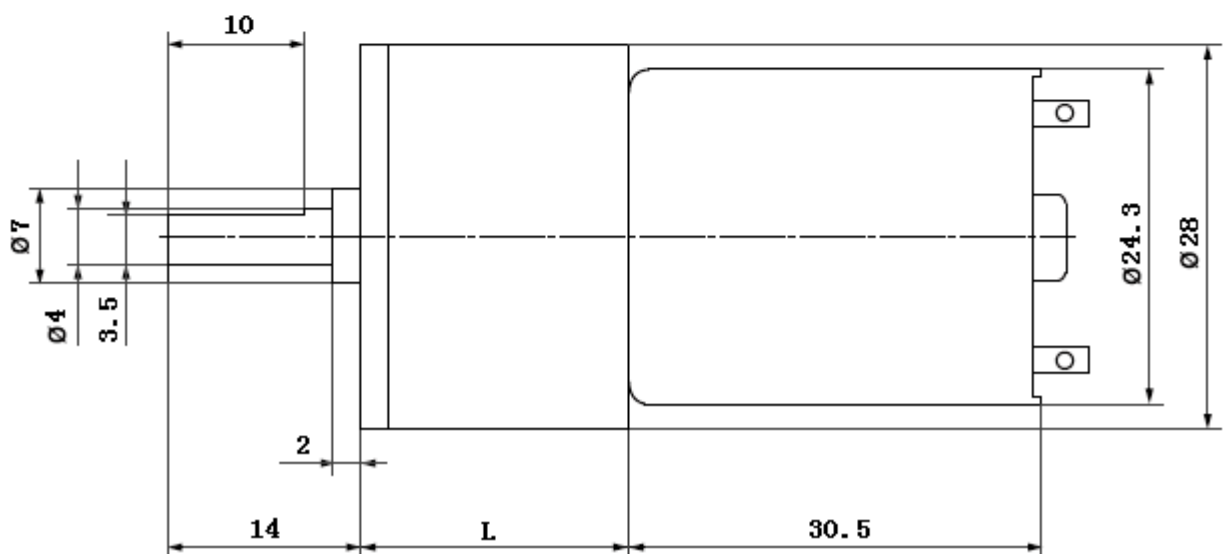

ZGA28RP

外形和安装尺寸

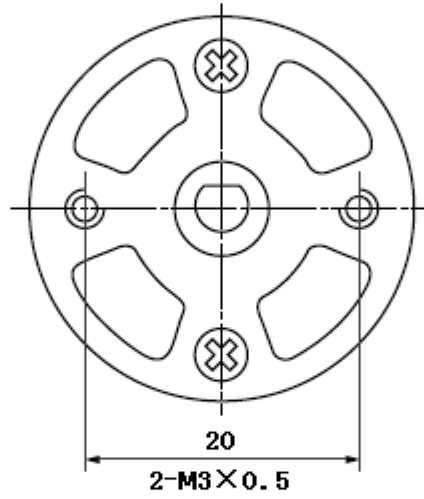
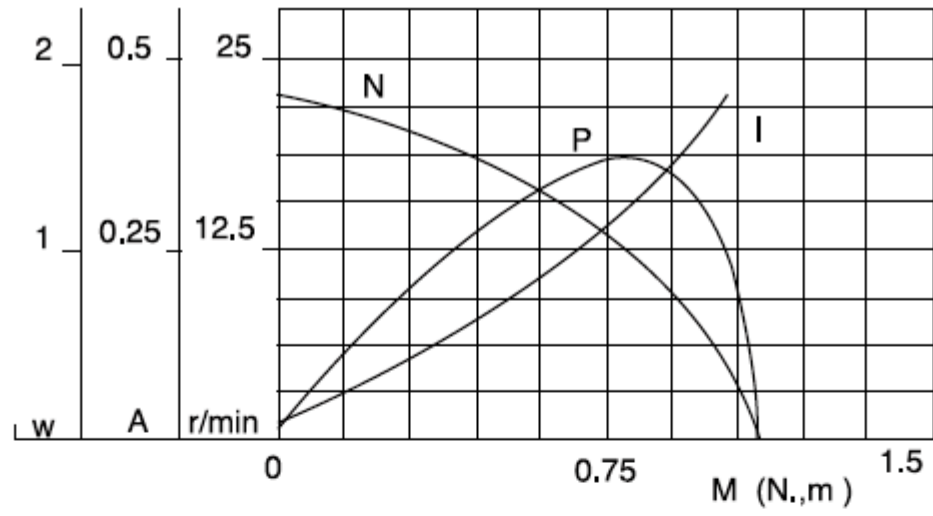

技术参数

i	31	74	174	412	974
L	19.5	22.7	24.7	26.7	30

电机型号(Type)	28L(Q)	WRF-370(P)	FRS-385(O)
尺寸(size)	ø27×23.2	ø24.3×32.3	ø27.5×40

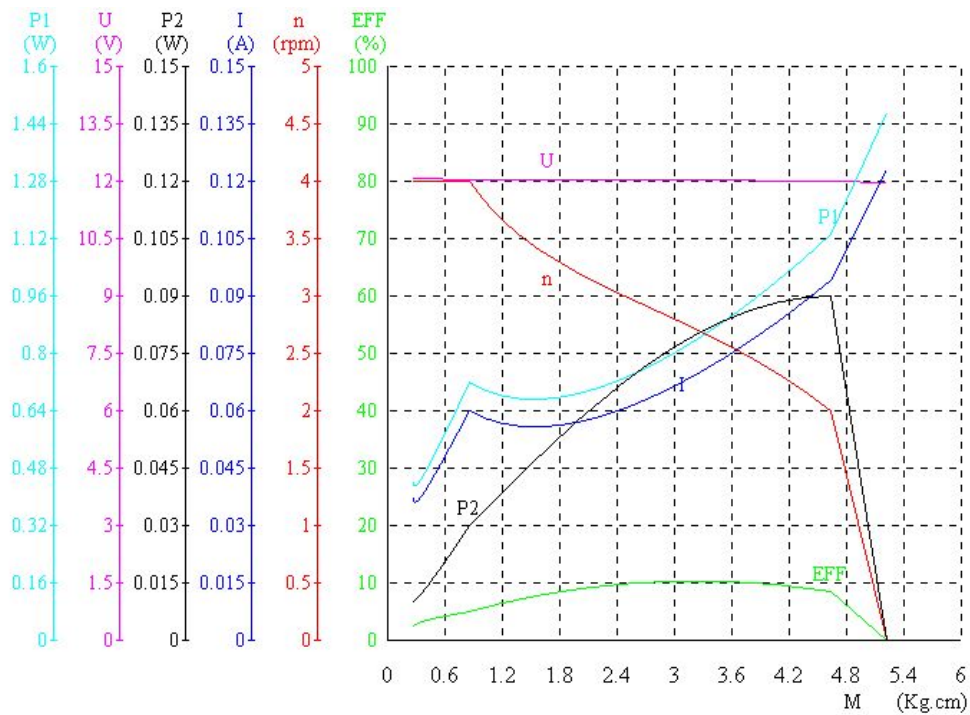

项目 (Descriptor)	U	I	P1	M	n	P2	Eff
	(V)	(A)	(W)	(Kg cm)	(rpm)	(W)	(%)
不加载点(No_Load)	12.05	0.037	0.44	0.27	4	0.01	2.4
最高效率点(Max_Eff)	12.01	0.062	0.75	3.10	3	0.09	12.6
最大输出功率点(Max_Pout)	11.99	0.094	1.13	4.64	2	0.09	8.3
最大转矩点(Max_Torque)	11.94	0.123	1.47	5.22	0	0.00	0.0
堵转点(Locked_Rotor)	11.94	0.123	1.47	5.22	0	0.00	0.0